

# ***Solid State Tesla Coil 1.0***

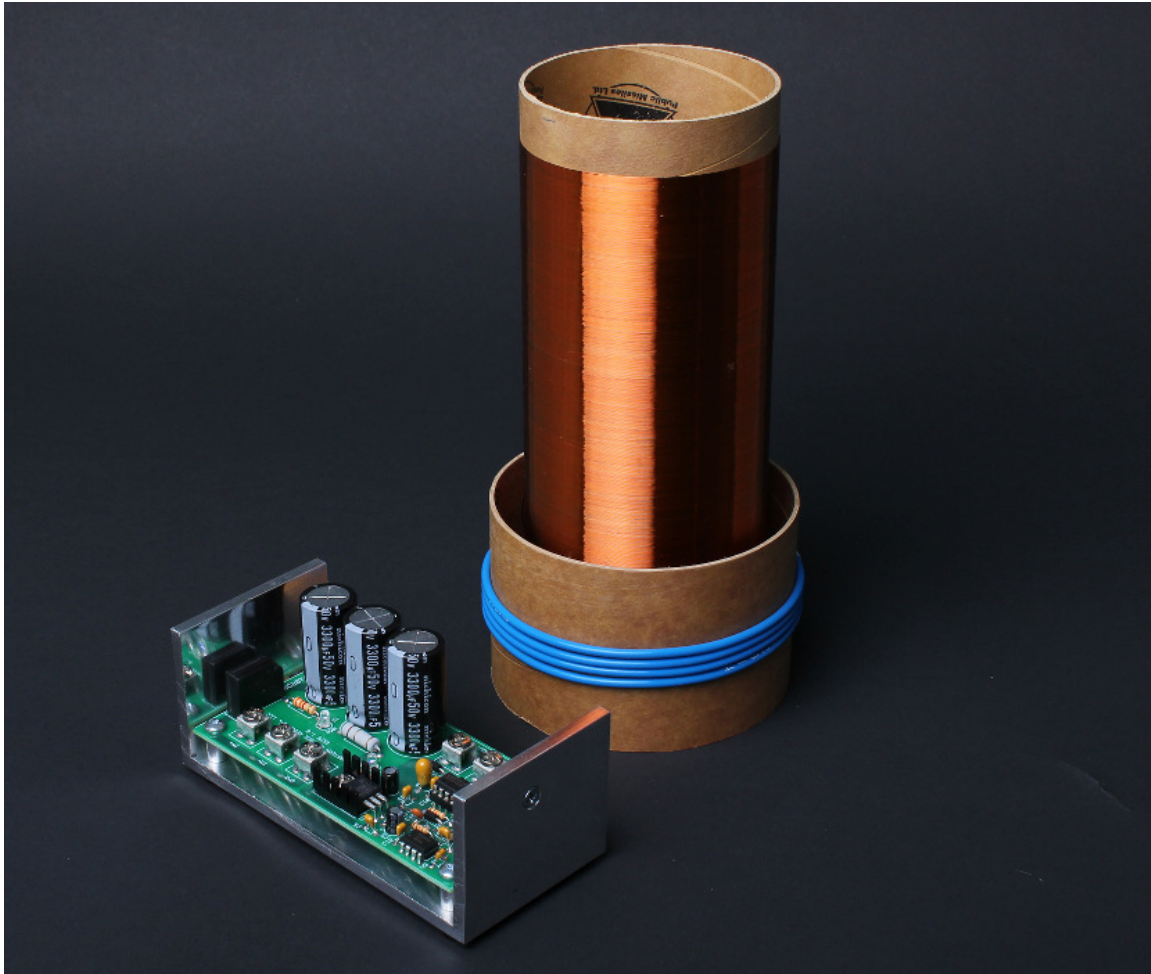

## ***Instruction Manual***

**Eastern Voltage Research, LLC**



## **AGE DISCLAIMER**

**THIS KIT IS AN ADVANCED, HIGH POWER SOLID STATE POWER DEVICE. IT IS INTENDED FOR USE FOR INDIVIDUALS OVER 18 YEARS OF AGE WITH THE PROPER KNOWLEDGE AND EXPERIENCE, AS WELL AS FAMILIARITY WITH LINE VOLTAGE POWER CIRCUITS.**

**BY BUILDING, USING, OR OPERATING THIS KIT, YOU ACKNOWLEDGE THAT YOU ARE OVER 18 YEARS OF AGE, AND THAT YOU HAVE THOROUGHLY READ THROUGH THE SAFETY INFORMATION PRESENTED IN THIS MANUAL.**

**THIS KIT SHALL NOT BE USED AT ANY TIME BY INDIVIDUALS UNDER 18 YEARS OF AGE.**



## **SAFETY AND EQUIPMENT HAZARDS**

**PLEASE BE SURE TO READ AND UNDERSTAND ALL SAFETY AND EQUIPMENT RELATED HAZARDS AND WARNINGS BEFORE BUILDING AND OPERATING YOUR KIT.**

**THE PURPOSE OF THESE WARNINGS IS NOT TO SCARE YOU, BUT TO KEEP YOU WELL INFORMED TO WHAT HAZARDS MAY APPLY FOR YOUR PARTICULAR KIT.**



## **PACEMAKER WARNING**

**THIS DEVICE WHEN CONNECTED TO A RESONATOR WILL PRODUCE ELECTRICAL AND MAGNETIC FIELDS. EXPOSURE TO THIS FIELD SHOULD BE LIMITED. DO NOT USE THIS KIT IF YOU HAVE AN IMPLANTED PACEMAKER OR OTHER BIOMEDICAL DEVICE!**



## **VARIAC WARNING**

**DO NOT USE A VARIAC WITH THIS PRODUCT. THIS PRODUCT REQUIRES POWER THROUGH AN ISOLATED TRANSFORMER (SUCH AS THE ONES PROVIDED IN THE KITS). A VARIAC IS NOT ISOLATED AND USING A VARIAC WITH THIS PRODUCT WILL CAUSE A SHORT CIRCUIT TO OCCUR WHICH WILL RESULT IN PERMANENT DAMAGE TO THE CIRCUITS.**



### **ELECTRICAL HAZARD**

**This circuit utilizes dangerous line voltages up to 115VAC. Failure to handle this circuit in a safe manner may result in serious injury or death!**



### **POWER SEMICONDUCTOR HAZARD**

**This is a solid state power device. Components may fail explosively at any time and eject high velocity projectiles. EYE PROTECTION IS REQUIRED AT ALL TIMES!**



### **ELECTROMAGNETIC FIELD HAZARD**

**This device when connected to a resonator will produce strong electric and magnetic fields. Exposure to this field should be limited. DO NOT USE THIS KIT IF YOU HAVE AN IMPLANTED BIOMEDICAL DEVICE!**



## **FIRE HAZARD**

**Due to high power dissipations of the the various semiconductors devices attached to the heatsink, the heatsink may become extremely hot, especially during periods of continuous operation. Please ensure the heatsink is not installed on or near any flammable material and that a cooling fan is ALWAYS used during operation.**

## **SAFETY GUIDELINES FOR LINE POWERED EQUIPMENT**

The electronic kit you purchased utilizes line voltages (115VAC) and also contains circuitry that produces output voltages in excess of 400VDC. Normally, consumer electronics equipment are safely enclosed to prevent accidental contact. However, the kit you have purchased does not come with an enclosure, and must be handled and operated with this in mind. Voltages exceeding 35V pose a safety hazard and depending on overall conditions and your general state of health, voltage and current levels have the ability to serious harm or even kill.

The following guidelines are to protect you from potentially lethal electrical shock hazards as well as the equipment from accidental damage.

It is also important to note that the danger isn't limited to only your body providing a conductive path, namely your heart. Any involuntary muscle contractions caused by an electrical shock, while perhaps harmless in themselves, may cause the person to be injured by falling, hitting a body part on something sharp, etc....

The purpose of these set of guidelines is not to frighten you, but rather make you aware of the appropriate precautions needed to safely build and operate this electronics kit.

- Perhaps, the number one rule – Don't work alone! If something does happen, it is extremely important to have someone nearby to render assistance or to call for help.
- When working on energized equipment (namely those that are line powered), always keep one hand in your pocket. This ensures there is not a complete electrical path through your heart providing you accidentally make contact with live voltage.
- Wear footwear with non-conductive (rubber) soles. Do NOT work on line powered or high voltage equipment in barefeet.
- Always wear eye protection. Power semiconductor devices, and capacitors do have the potential to explode unexpectedly and project sharp fragments across the room.
- Always work in a clean, open area. Avoid working in cluttered spaces, especially if there are grounded objects nearby that could complete a circuit path in the event you make accidental contact with live voltage.
- Avoid wearing any kind of jewelry or other articles that could accidentally contact circuitry.
- Never operate your PC boards on top of conductive tables, or other conductive objects. PC boards should ALWAYS be supported by the provided stand-offs or placed on top of a non-conductive tabletop or other material.
- ALWAYS allow proper time for any large electrolytic or other high voltage capacitors to discharge after removing power prior to working or touching any



circuit. ALWAYS use a multimeter to measure the voltage across large capacitors after power is disconnect to ensure the voltage has properly bled off.

- Use an isolation transformer if there is any chance of contacting line powered circuitry. A Variac is NOT an isolation transformer!
- Finally, if your kit involves a Tesla Coil – NEVER touch or attempt to draw an arc with an object from the output of a Tesla Coil. The output of a Tesla Coil poses not only an electrical hazard, but also a burn hazard. The output from even the smallest solid state Tesla Coil can cause serious burns. Always operate the Tesla Coil at a safe distance.

## **SAFETY GUIDELINES - SEMICONDUCTOR POWER DEVICES**

- Always wear eye protection. Power semiconductor devices, and capacitors do have the potential to explode unexpectedly and project sharp fragments across the room.
- Power semiconductors may be extremely hot. NEVER touch any semiconductors during operation or after use. Always allow proper time for components to cool down prior to handling them.

## **SAFETY GUIDELINES – HIGH TEMPERATURE COMPONENTS**

- Power semiconductors may be extremely hot. NEVER touch any semiconductors during operation or after use. Always allow proper time for components to cool down prior to handling them.
- The extruded aluminum heatsink will be extremely hot during and after use until it cools down to ambient temperature. NEVER place the heatsink on any material that is flammable such as wood, plastic, or paper. It is preferable to place the extruded aluminum heatsink onto a metal plate.
- NEVER operate the device without the use of a cooling fan. If you are using an extruded aluminum heatsink, be sure to blow fan parallel to the cooling fins of the heatsink to maximize the cooling effects of the fan. Always allow the cooling fan to continue running, even after power is removed, until the heatsink and board components are properly “cooled” down.

**SAFETY GUIDELINES – ELECTROMAGNETIC FIELD OUTPUT**



**DO NOT USE THIS KIT if you have an implanted biomedical device such as a pacemaker!**

- Electromagnetic fields are produced when the Tesla coil is operating. Ensure that you and others are always at least five feet away from the devices during operation (small kits), and farther away with some of the larger kits such as the miniBrute Tesla Coil kit.
- Avoid contact with metallic objects. This is mostly important for the smaller CW based Tesla coils such as the SSTC 1.0 or Class-E Audio Modulated Tesla Coil. What happens is that the electromagnetic fields cause charge to build up on your person and any contact with something metallic will initiate a potential RF burn to occur. The burns are on the magnitude of an electrostatic shock – they are rarely harmful, but they can surprise you and give you a small instant of localized pain – again similar in receiving an electrostatic shock. Maintaining at least five feet away from the Tesla coil will prevent this from occurring.
- DO NOT use this kit if you have an implanted biomedical device.

## **Introduction to the Solid State Tesla Coil 1.0**

Thank you for purchasing the SSTC 1.0 Kit. The SSTC 1.0 is an incredibly simple Tesla coil that is an excellent choice for both beginners and seasoned enthusiasts alike. Its an extremely popular choice for middle school and high school science fair projects. The small coil produces output arcs up to 2.0” in length, and easily illuminates fluorescent and neon lights with the electric field it creates. It also features a self-resonant feedback circuit which tunes the coil automatically. No need to spend time tuning and re-tuning your coil. Just turn on the Tesla coil and watch the high voltage spring into action!

Notice to Beginners: If you are first time kit builder, you may find this instruction manual easier to understand than expected. Each component in this kit has an individual check box, while a detailed description of each component is provided as well. If you follow each step in the instruction manual in order, and practice good soldering and kit building skills, the kit is next to fail-safe.



**Please read this manual in its entirety before building, testing, or operating your kit!**

## **Circuit Description**

The SSTC 1.0 is a very simple circuit comprised of only a few major subcircuits. The low voltage 24VAC transformer, T1, along with bridge rectifier, BR1, and filter capacitors, C1,C2, and C3, provide the DC voltage required to power the Tesla coil and its control circuitry. The 7812 linear regulator, U1, provides 12VDC which is used to provide power to the control and driver circuits. Because the Tesla coil is self-resonating, it requires something to sample the output high voltage and feed it back into the control circuit providing positive feedback. This is accomplished through the use of a wire antenna which “picks up” the electric field of the Tesla coil. However, because the control drive circuitry requires the high voltage of the Tesla coil to provide the positive feedback necessary to self-oscillate, an external pulse is required to “start” the oscillation process. This is simply accomplished through the use of an external pulse circuit which is comprised of a single 555 Timer. The 555 Timer continuously outputs pulses which will cause the circuit to begin oscillation. Once oscillation begins, the feedback from the antenna will “overpower” the output of the 555 Timer and take over control of the drive circuit. Finally, the primary solid state power stage of this coil is made-up of the gate driver IC, U2, and high power switching transistor (200V N-Channel MOSFET), Q1. Due to the self-resonating feedback network, Q1 will always switch at the exact resonant frequency of the Tesla resonator, and thus never requires manual tuning.

## Kit Building Tips

A good soldering technique is key! Let your soldering iron tip gently heat both the wires and pads simultaneously. Apply solder to the wire and the pad when the pad is hot enough to melt the solder. The finished joint should appear like a small shiny drop of water on paper, somewhat soaked in. If the pads have not heated up sufficiently, melted solder (heated only by the soldering iron itself) will form a cold solder joint and will not conduct properly. These cold joints appear as dull beads of solder, and can be easily fixed by applying additional heat to the pad and wire. All components, unless otherwise noted, should be mounted on the top side of the board. This is the side with the silkscreen printing.

When installing components, the component is placed flat to the board and the leads are bent on the backside of the board to prevent the part from falling out before soldering. The part is then soldered securely to the board, and the remaining lead length is clipped off. It is also extremely important to place the components as close to the board as possible. This is necessary for proper operation over the wide frequency range of the various kits we provide. Also be sure that component lead lengths are always as short as possible. This will avoid adding any stray capacitances or inductances that can be detrimental to circuit operation.

An alternative approach (which is actually the one I use) is to install the component into the board and then apply a piece of masking tape on the topside to hold the component in place temporarily. The leads on the backside of the board are then trimmed leaving about 0.10" lead protruding through the backside of the board, and then soldered from the backside. You can then remove the masking tape, and finally apply a small amount of solder on the top to complete the joint on both sides. This is shown in the figure below.

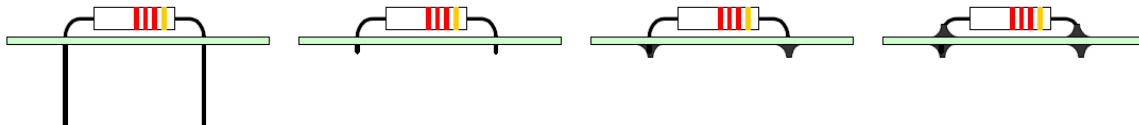

**SSTC 1.0 Parts List****RESISTORS**

- 1 33 ohm Resistor, 2W (orange-orange-black), R1
- 1 3.3k Resistor 1/2W (orange-orange-red), R2
- 1 820, Resistor (gray-red-brown), R3
- 1 100k, Resistor (brown-black-yellow), R5
- 1 5.1, Resistor, 2W (green-brown-gold), R6
- 1 10k Resistor (brown-black-red), R4
- 1 20k Resistor (red-black-orange), R8

**CAPACITORS**

- 3 2200uF (or 3300uF) Electrolytic Capacitor, C1,C2,C3
- 2 10uF, 50V Electrolytic Capacitor, C5,C7
- 1 10uF,35V Tantalum Capacitor, C9
- 4 0.1uF Ceramic Capacitor, C6,C8,C10,C12
- 1 0.01uF Ceramic Capacitor, C14
- 1 330pF Ceramic Capacitor, C13
- 1 1000pF 3kV Capacitor, C11

**DIODES**

- 1 1N4002 Diode (marked 1N4002), CR1
- 4 1N5819 Diode (marked 1N5819), CR2,CR3,CR4,CR5
- 2 LED, Blue (or Red), D1, D2
- 1 Bridge Rectifier, BR1

**SEMICONDUCTORS**

- 1 IRFP260 MOSFET, Q1

**INTEGRATED CIRCUITS (ICs)**

- 1 12V Regulator (marked LM7812), U1
- 1 Gate Driver (marked UCC37322), U2
- 1 555 Timer (marked 555), U3

**MISCELLANEOUS**

- 1 8DIP IC Socket
- 6 Screw Terminals
- 1 Power Transformer
- 1 3.1" DIA Coilform, 8" Length
- 1 3.9" DIA Coilform, 2.5" Length
- 1 Coilform Centering Ring
- 1 30AWG Magnet Wire, 500-800 Ft.
- 1 Heatsink, U-Channel
- 1 Misc. Hardware
- 1 AC Power Cord
- 1 Antenna Wire, 22-26AWG, 14"
- 1 Black Grounding Wire
- 4 Adhesive Rubber Feet
- 1 Adhesive Thermal Insulator
- 2 Fuse Clip, PC Mount (REV 1 PCB only)
- 1 Fuse, 5A, 5x20mm, Fast Acting (REV 1 PCB only)

**REQUIRED, NOT SUPPLIED**

- A/R Electrical Tape or Wire Nuts
- A/R Two-Part Epoxy or similar adhesive

**RECOMMENDED, NOT SUPPLIED**

- 1 Enclosure for SSTC 1.0 Board

SSTC 1.0 Component Layout Diagram (Rev B PCB)

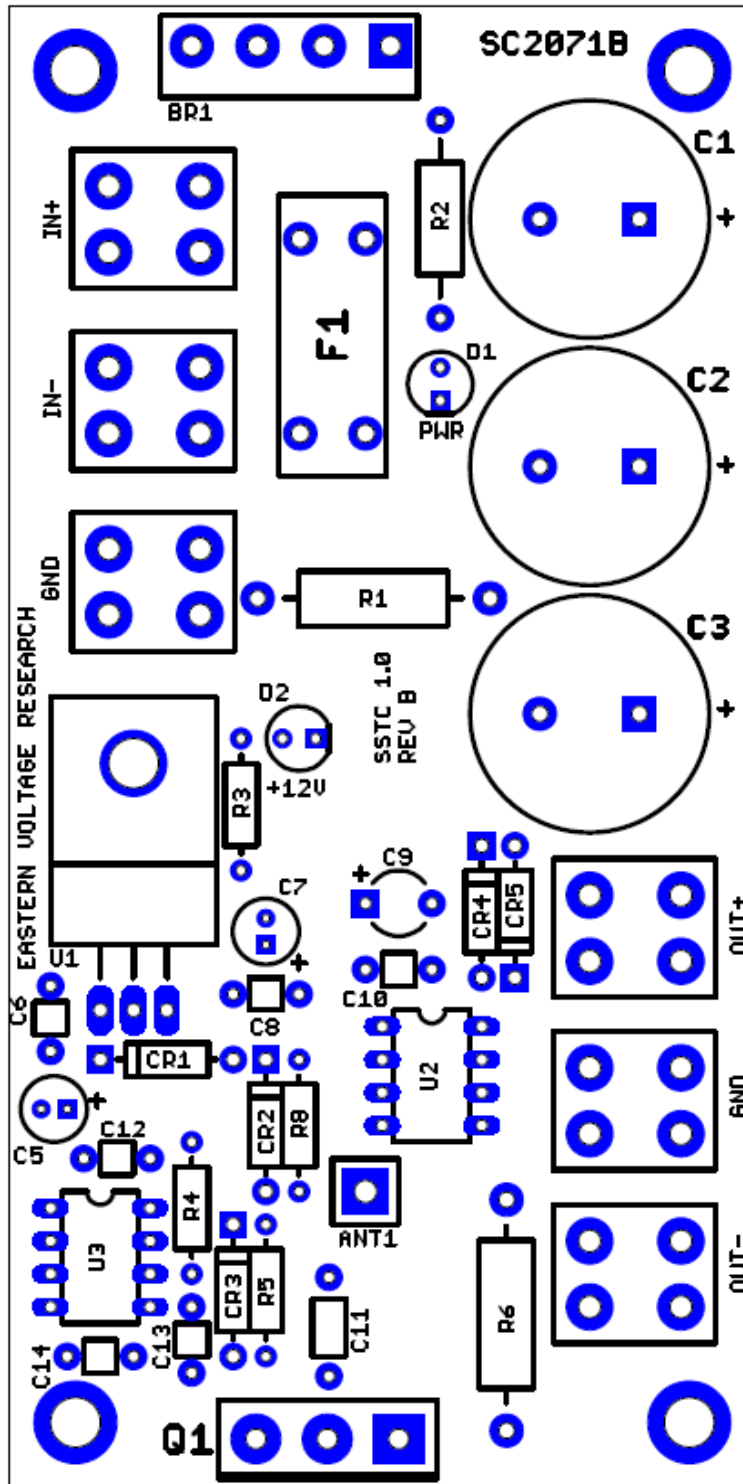

## KIT Building Instructions

Now we will begin building the kit. There are just a few more important things to know before we install the first components.

For each component, the word “install” always means the following:

1. Pick the correct value to start with.
2. Insert the component into the correct printed circuit board (PCB) location.
3. Orient the component correctly – especially when there is a right and a wrong way to solder it in. (i.e. electrolytic capacitors, diodes, ICs, transistors, etc...)
4. Solder all connections unless directed otherwise. Ensure enough heat is used to allow solder to flow for clean, shiny, and completed connections.

Also, please be sure to take us seriously when we say that good soldering is the key to the proper operation of your circuit!

- Use a 25W soldering pencil with a clean, sharp tip. **DO NOT USE** a high power soldering gun such as those trigger activated units.
- Use only rosin core solder intended for electronics use
- Ensure your work area is clean, and has plenty of bright lighting
- Build your kit in stages, taking breaks to check your work. Be sure to clean the board periodically with a brush or compressed air to remove any excess wire cuttings, etc...

Okay, so lets begin!

- 1. Install R1, 33 ohm, 2W resistor (orange-orange-black)
- 2. Install R2, 3.3k, 1/2W resistor (orange-orange-red)
- 3. Install R3, 820 ohm resistor (gray-red-brown)
- 3. Install R4, 10k resistor (brown-black-orange)
- 4. Install R5, 100k resistor (brown-black-yellow)
- 5. Install R6, 5.1 ohm, 2W resistor (green-brown-gold)
- 6. Install R8, 20k resistor (red-black-orange)
- 7. Install CR1, 1N4002 diode. The cathode band on the diode must match that shown on the silkscreen.



- 8. Install CR2, 1N5819 diode. The cathode band on the diode must match that shown on the silkscreen.
- 9. Install CR3, 1N5819 diode. The cathode band on the diode must match that shown on the silkscreen.
- 10. Install CR4, 1N5819 diode. The cathode band on the diode must match that shown on the silkscreen.
- 11. Install CR5, 1N5819 diode. The cathode band on the diode must match that shown on the silkscreen.
- 12. Install C6, 0.1uF capacitor (marking BC104)
- 13. Install C8, 0.1uF capacitor (marking BC104)
- 14. Install C10, 0.1uF capacitor (marking BC104)
- 15. Install C12, 0.1uF capacitor (marking BC104)
- 16. Install C13, 330pF capacitor (marking BC331 or M39014/01-1308V)
- 17. Install C14, 0.01uF capacitor (marking BC103)
- 18. Install C1, 2200uF (3300uF), electrolytic capacitor. C1 has “polarity.” Polarity means the capacitor must be inserted a certain way. You may notice that one side of the capacitor, there is a black stripe with minus signs. This is the negative end. Looking at the PCB silkscreen, you will notice the positive side marked. Install this capacitor into the board ensuring the positive side of the capacitor installs in the hole that is marked positive on the PCB layout.
- 19. Install C2, 2200uF (3300uF), electrolytic capacitor. Install this capacitor into the board ensuring the positive side of the capacitor installs in the hole that is marked positive on the PCB layout.
- 20. Install C3, 2200uF (3300uF), electrolytic capacitor. Install this capacitor into the board ensuring the positive side of the capacitor installs in the hole that is marked positive on the PCB layout.
- 21. Install C5, 10uF, 50V electrolytic capacitor. Install this capacitor into the board ensuring the positive side of the capacitor installs in the hole that is marked positive on the PCB layout.

- 22. Install C7, 10uF, 50V electrolytic capacitor. Install this capacitor into the board ensuring the positive side of the capacitor installs in the hole that is marked positive on the PCB layout.
- 23. Install C9, 10uF, 35V tantalum capacitor (marked 10635). Install this capacitor into the board ensuring the positive side of the capacitor installs in the hole that is marked positive on the PCB layout. The square pad is the positive side.
- 24. Install C11, 1000pF, 2kV capacitor (marking Z5U .001M 3kV)
- 25. Install D1, LED. The short lead of the diode is the cathode and will install into the square pad on the PCB board.
- 26. Install D2, LED. The short lead of the diode is the cathode and will install into the square pad on the PCB board.
- 27. Install an 8-pin DIP socket into the U2 location. Note that one end of the DIP socket is marked by a notch; this end **MUST** be oriented as shown on the PCB layout. **DO NOT INSTALL U2 at this time!**
- 28. Install U3, 555 Timer. The 555 Timer IC may be soldered directly to the PCB without worry, but you may use an 8-pin DIP socket (your own) if you prefer. Use the same care in soldering such a socket and inserting the IC as you would in direct soldering of the chip. Note that one end of the IC is marked by a dot, notch, or band; this end **MUST** be oriented as shown on the PCB layout.
- 29. Install U1, LM7812 Linear Regulator. This component must be installed with the included heatsink and hardware. The easiest way to solder this to the board is to first attach the component and heatsink / hardware to the board, ensuring the leads on U1 are properly bent (formed) to align with the solder holes and heatsink mounting hole. Once the heatsink assembly is attached, the three (3) leads of the LM7812 can be soldered to the PCB. Be sure not to bend the leads more than once as they will break!
- 30. Install BR1, bridge rectifier. The notched end of BR1 is the positive pin and must be installed in the square pad in the PCB board.
- 31. Install the two (2) fuse clips in the board location designated F1 on the PCB board. Note, that there are end-stops on each of these clips which must be facing the outside when installed, or the fuse will not install properly.
- 32. Install the 5A fuse into the F1 fuse clips.
- 33. Install the six (6) screw terminals.

- ❑ 34. Using the included 22-26 AWG wire, cut the wire to 14 inches in length and solder to the ANT terminal on the PCB board. This is the wire feedback antenna. The antenna must be installed on the top side of the board.
- ❑ 35. The U-channel heatsink that is included with your kit is unfinished and although efforts have been made to properly deburr all edges, some edges may still be sharp. So at this time, you may wish to smooth any remaining sharp edges with a handheld file and also polish the heatsink. You can polish the heatsink using very fine Scotch-Brite pads (usually found at your local hardware store) or with a motorized grinder using an attached metal polishing pad and compound.
- ❑ 36. Attach the four (4) threaded stand-offs using included flathead 6-32 hardware to the base of the heatsink. The PC board will sit on top of these stand-offs. Install the four (4) self-adhesive rubber feet to the bottom of the heatsink.
- ❑ 37. Using the included 6-32 panhead hardware, attach the PC board to the four (4) threaded stand-offs. The board should be oriented so that the component mounting hole in the heatsink align with the component location Q1 on the PC board.
- ❑ 38. Attach the self-adhesive thermal insulator to the heatsink in the position where Q1 will be mounted. Ensure that the thermal insulator is positioned so that the entire component fits on it. (No overlapping)
- ❑ 39. Install Q1, IRFP260 MOSFET. With the PCB board mounted to the heatsink, first insert Q1 into the board. Do NOT solder Q1 at this time. The metalized back of Q1 will be the side that attaches to the heatsink. Using the included hardware, attach Q1 to the heatsink (ensure the thermal insulator is also in place). Once Q1 is attached to the heatsink, solder it to the board. This ensures that the fit and alignment of Q1 will match the heatsink mounting hole.
- ❑ 40. Now the fun part – winding the secondary coil. Using the figure below, wind the secondary coil using the included 30AWG spool of wire. First place the spool of wire on a stationary rod so that it can spin freely. Next, wind a few extra turns at the base of the secondary and use masking or electrical tape to hold in place. Begin winding the secondary at the locations shown in the figure below. Continue winding the secondary, ensuring each wind is neat and tightly together with adjacent windings, for the entire length as indicated in the figure below. Adding masking tape every inch or so will ensure the windings don't unwind and also allows you to take rests if needed. Once you are completed, tape off the end of the winding, and finally add a few extra turns. For finishing the coil, you have the option of leaving it as is, wrapping it with masking or electrical tape, or for a more professional look, simply coating it with polyurethane furniture finish which can be purchased at any hardware or home improvement store.

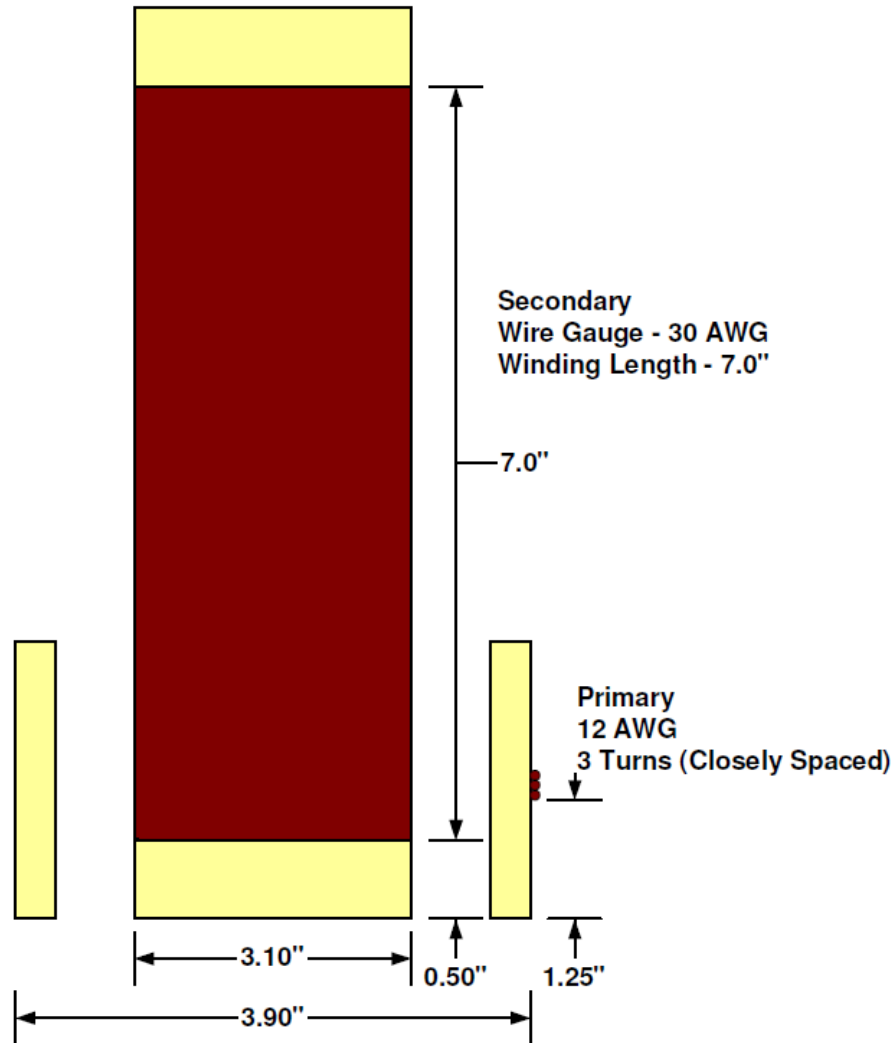

- 41. Using the included 12 AWG wire, wind the primary coil as shown in the figure above. The primary coil can then be secured in place using masking or electrical tape (not supplied), or two-part epoxy (not supplied).
- 42. Assemble the primary and secondary coils using the included centering ring. Use wood glue or epoxy (not supplied) to permanently affix in place.
- 43. Solder the included black ground wire to the bottom of the secondary coil as shown in the hook-up diagram below. You will need to use sandpaper (not supplied) to remove the enamel from the magnet wire prior to soldering it.

- 44. Form the top wire of the secondary into a discharge electrode as shown in the figure below.

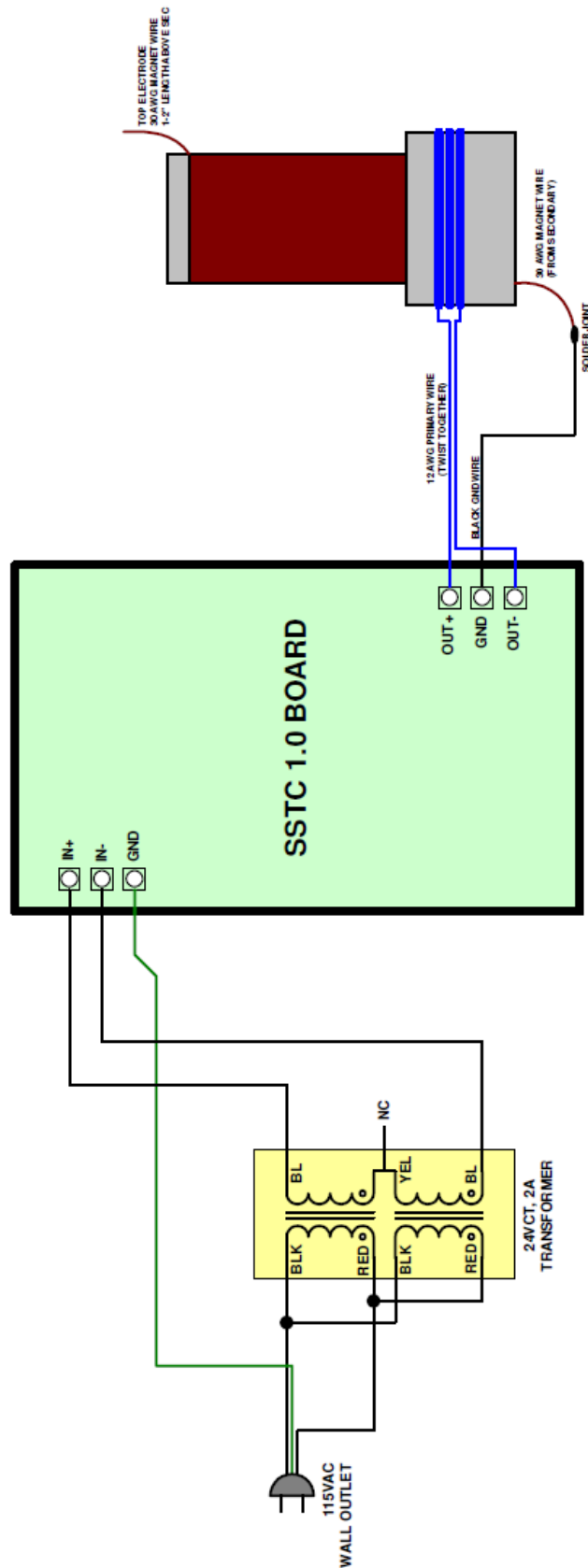

- 45. Install T1, power transformer as shown in the diagram above. It is very important to attach the ground wire of the AC cord to the GND terminal on the PCB board. Use electrical tape or wirenuts (not supplied) to secure and insulate the connections between the power transformer and AC cord.

**DO NOT connect the primary coil to the PCB board at this time.**

Congratulations! You have just completed your SSTC 1.0 kit. Please take a few moments to look over the board and ensure that all the components are installed properly with the correct orientation. Since some of the parts may be unfamiliar to you, you may want to be extra sure that they have been inserted correctly. After you are sure that everything seems to be properly installed, move on to the set-up and testing section.

## Set-up and Testing

Okay, so lets begin!

### RECOMMENDED TEST EQUIPMENT, NOT SUPPLIED

- 1 Analog or Digital Multimeter



**Please be sure to wear safety glasses when testing and operating the SSTC 1.0.**

- 1. After putting on your safety glasses, plug in the 120VAC power cord. Note that both U2 (UCC373232) and the primary coil should NOT be installed at this time. Using a multimeter, verify that the following voltages are correct. If they are not, then there is a problem with your circuit that needs to be diagnosed and corrected.

Check	Component	Measuring Point	Voltage
<input type="checkbox"/>	BR1	Pin 1 (Positive)	22V $\pm$ 2V
<input type="checkbox"/>	U1	Pin 1 (Input)	14V to 18V
<input type="checkbox"/>	U1	Pin 3 (Output)	12V $\pm$ 0.5V
<input type="checkbox"/>	U2	Pin 1 (Vcc)	12V $\pm$ 0.5V
<input type="checkbox"/>	U2	Pin 8 (Vcc)	12V $\pm$ 0.5V
<input type="checkbox"/>	U2	Pin 3 (Enable)	12V $\pm$ 0.5V
<input type="checkbox"/>	U3	Pin 8 (Vcc)	12V $\pm$ 0.5V
<input type="checkbox"/>	U3	Pin 4 (Reset)	12V $\pm$ 0.5V

Note: All voltages should be measured with respect to the GND screw terminal.

- 2. Verify that both LEDs, D1 and D2, are illuminated. If they are not, and the voltages above are correct, they may be installed backwards.
- 3. Unplug the 120VAC power cord. Due to the capacitor storage on the board, it may take about 10 seconds for the power to bleed off. Wait until the LEDs completely turn off before proceeding to the next step.
- 4. Install U2, UCC37322 Gate Driver. Note that one end of the IC is marked by a dot, notch, or band; this end **MUST** be oriented as shown on the PCB layout.
- 5. Install the wires of the primary coil to the screw terminals labeled OUT+ and OUT- on the board. Be sure that the primary wires are twisted tightly together from the Tesla primary coil to the PC board screw terminals.
- 6. Verify that the ground connection from the bottom of the secondary coil is properly connected to the GND screw terminal on the PC board as shown in the hook-up diagram above. Also ensure there is about 1-2" length of secondary wire protruding above the secondary coil. This will act as the discharge electrode.
- 7. Orient the antenna so that is near the Tesla coil, but not touching it.
- 8. Plug in the 120VAC power cord.
- 9. If everything was installed properly, your Tesla coil should now be self-oscillating and producing an output arc. If it is not, turn off power and then reverse the primary wire connections at the OUT+ and OUT- screw terminals. Once output arc is being produced, move the antenna around until you get maximum arc output.

Congratulations! Your SSTC 1.0 Tesla Coil is now completed and operational. Try gathering some old fluorescent bulbs and placing them close to the Tesla coil. The electric fields generated by the Tesla coil will illuminate the fluorescent bulbs without the use of wires!



**The Output Arc of the Tesla Coil is extremely hot. Never attempt to touch the arc or draw arcs using any type of object.**



## **Troubleshooting**

**PROBLEM:** No output arc. (Blue LEDs illuminated)

**SOLUTION:** This is typically due to the polarity of the primary being incorrect. Simply reverse the primary connections at OUT+ and OUT- on the PC board.

**PROBLEM:** No output arc. (Blue LEDs are not working)

**SOLUTION:** In this case, either U2 or Q1 has probably failed. Your unit will require diagnose and repair.

**PROBLEM:** Output arc is very small

**SOLUTION:** The antenna needs to be oriented and placed properly to get maximum arc. Try moving the antenna around in relation to the Tesla coil until maximum arc is observed.

## **Conclusion**

We sincerely hope that you have enjoyed the construction of this Eastern Voltage Research Kit. As always, we have tried to write this instruction manual in the easiest, most “user friendly” format that is possible. As our customers, we value your opinions, comments, and additions that you would like to see in future publications. Please submit comments or ideas to:

Eastern Voltage Research, LLC

Technical Support  
support@easternvoltage.com

Thanks again from the people here at Eastern Voltage Research.

## **Terms and Conditions of Sale**

Before opening or assembling your kit, please read and review the latest Terms and Conditions of Sale on our website at the following link:

<http://www.easternvoltage.com/terms.html>

**Military Dash Number Identification (M39014/01-xxxx) – Ceramic Capacitors**

Failure Rate Level (%/1,000 Hours)				Capacitance (pF)	Capacitance Tolerance ±Percent	WVDC
1.0 (M)	0.1 (P)	0.01 (R)	0.001 (S)			
<b>CKR05 (BX)</b>						
1201	1241	1281	1321	10	10	200
1202	1242	1282	1322	10	20	200
1203	1243	1283	1323	12	10	200
1204	1244	1284	1324	15	10	200
1205	1245	1285	1325	15	20	200
1206	1246	1286	1326	18	10	200
1207	1247	1287	1327	22	10	200
1208	1248	1288	1328	22	20	200
1209	1249	1289	1329	27	10	200
1210	1250	1290	1330	33	10	200
1211	1251	1291	1331	33	20	200
1212	1252	1292	1332	39	10	200
1213	1253	1293	1333	47	10	200
1214	1254	1294	1334	47	20	200
1215	1255	1295	1335	56	10	200
1216	1256	1296	1336	68	10	200
1217	1257	1297	1337	68	20	200
1218	1258	1298	1338	82	10	200
1219	1259	1299	1339	100	10	200
1220	1260	1300	1340	100	20	200
1221	1261	1301	1341	120	10	200
1222	1262	1302	1342	150	10	200
1223	1263	1303	1343	150	20	200
1224	1264	1304	1344	180	10	200
1225	1265	1305	1345	220	10	200
1226	1266	1306	1346	220	20	200
1227	1267	1307	1347	270	10	200
1228	1268	1308	1348	330	10	200
1229	1269	1309	1349	330	20	200
1230	1270	1310	1350	390	10	200
1231	1271	1311	1351	470	10	200
1232	1272	1312	1352	470	20	200
1233	1273	1313	1353	560	10	200
1234	1274	1314	1354	680	10	200
1235	1275	1315	1355	680	20	200
1236	1276	1316	1356	820	10	200
1237	1277	1317	1357	1,000	10	200
1238	1278	1318	1358	1,000	20	200
1239	1279	1319	1359	1,200	10	100
1240	1280	1320	1360	1,500	10	100
1441	1481	1521	1561	1,500	20	100
1442	1482	1522	1562	1,800	10	100
1443	1483	1523	1563	2,200	10	100
1444	1484	1524	1564	2,200	20	100
1445	1485	1525	1565	2,700	10	100
1446	1486	1526	1566	3,300	10	100
1447	1487	1527	1567	3,300	20	100
1448	1488	1528	1568	3,900	10	100
1449	1489	1529	1569	4,700	10	100
1450	1490	1530	1570	4,700	20	100
1451	1491	1531	1571	5,600	10	100
1452	1492	1532	1572	6,800	10	100
1453	1493	1533	1573	6,800	20	100
1454	1494	1534	1574	8,200	10	100
1455	1495	1535	1575	10,000	10	100
1456	1496	1536	1576	10,000	20	100
1457	1497	1537	1577	12,000	10	50
1458	1498	1538	1578	15,000	10	50
1459	1499	1539	1579	15,000	20	50
1480	1500	1540	1580	18,000	10	50
1461	1501	1541	1581	22,000	10	50
1462	1502	1542	1582	22,000	20	50
1463	1503	1543	1583	27,000	10	50
1464	1504	1544	1584	33,000	10	50
1465	1505	1545	1585	33,000	20	50
1466	1506	1546	1586	39,000	10	50
1467	1507	1547	1587	47,000	10	50
1468	1508	1548	1588	47,000	20	50
1469	1509	1549	1589	56,000	10	50
1470	1510	1550	1590	68,000	10	50
1471	1511	1551	1591	68,000	20	50
1472	1512	1552	1592	82,000	10	50
1473	1513	1553	1593	100,000	10	50
1474	1514	1554	1594	100,000	20	50

Military Dash Number Identification (M39014/02-xxxx) – Ceramic Capacitors

Failure Rate Level (%/1,000 Hours)				Capacitance (pF)	Capacitance Tolerance ±Percent	WVDC
1.0 (M)	0.1 (P)	0.01 (R)	0.001 (S)			
<b>CKR06 (BX)</b>						
1201	1241	1281	1321	1200	10	200
1202	1242	1282	1322	1500	10	200
1203	1243	1283	1323	1500	20	200
1204	1244	1284	1324	1800	10	200
1206	1246	1286	1326	2200	10	200
1207	1247	1287	1327	2200	20	200
1208	1248	1288	1328	2700	10	200
1209	1249	1289	1329	3300	10	200
1210	1250	1290	1330	3300	20	200
1211	1251	1291	1331	3900	10	200
1212	1252	1292	1332	4700	10	200
1213	1253	1293	1333	4700	20	200
1214	1254	1294	1334	5600	10	200
1215	1255	1295	1335	6800	10	200
1216	1256	1296	1336	6800	20	200
1217	1257	1297	1337	8200	10	200
1218	1258	1298	1338	10,000	10	200
1219	1259	1299	1339	10,000	20	200
1231	1271	1311	1351	12,000	10	100
1220	1260	1300	1340	15,000	10	100
1221	1261	1301	1341	18,000	10	100
1222	1262	1302	1342	22,000	10	100
1232	1272	1312	1352	27,000	10	100
1223	1263	1303	1343	33,000	10	100
1224	1264	1304	1344	39,000	10	100
1225	1265	1305	1345	47,000	10	100
1226	1266	1306	1346	56,000	10	100
1227	1267	1307	1347	68,000	10	100
1229	1269	1309	1349	82,000	10	100
1230	1270	1310	1350	100,000	10	100
1233	1273	1313	1353	120,000	10	50
1234	1274	1314	1354	150,000	10	50
1235	1275	1315	1355	180,000	10	50
1236	1276	1316	1356	220,000	10	50
1237	1277	1317	1357	270,000	10	50
1238	1278	1318	1358	330,000	10	50
1239	1279	1319	1359	390,000	10	50
1240	1280	1320	1360	470,000	10	50
1404	1408	1412	1416	560,000	10	50
1405	1409	1413	1417	680,000	10	50
1406	1410	1414	1418	820,000	10	50
1407	1411	1415	1419	1,000,000	10	50